

ADVANCED TOPICS IN DIGITAL SIGNAL PROCESSING

An Examination of DSP in Modern Fourth Generation Modems

fred harris
San Diego State University



Advanced Topics in Digital Signal Processing

An Examination of DSP in Modern Fourth Generation Modems

June 21-24, 2004

8:30am - 4:30pm

Washington DC/Maryland

\$1495

Summary

This four-day course is designed for communication systems engineers, programmers, implementers and managers who need to understand current practice and next generation DSP techniques for upcoming communication systems. DSP is more than mapping legacy analog designs to a DSP implementation. To avoid compromise solution appropriate for an earlier time period, we return to first principles to learn how to apply new technology capabilities to the design of next generation communication systems.

Instructor

Dr. fred harris teaches at San Diego State University where he occupies the CUBIC Signal Processing Chair. His teaching and research areas include Digital Signal Processing, Multirate Signal Processing, Communication Systems, Source Coding and Modem Design. He has extensive practical experience in communication systems, high performance modems, sonar and advanced radar systems and high performance laboratory instrumentation. He holds a number of patents on Multirate Signal Processing for Satellite and Cable Modems and lectures throughout the world on DSP applications. He consults for organizations requiring high performance, cost-effective DSP solutions and has contributed to a number of textbooks and handbooks on various aspects of signal processing.

What You Will Learn

- How to size and design filters for a specified processing task
- Effects of Finite Arithmetic on Different Filter Architectures
- Understand Multi-rate Signal processing for Sample Rate Changes
- Understand Multi-rate Signal processing for Intentional Aliasing
- DSP Based Signal Enhancement and Signal Conditioning
- DSP Based Synchronization Techniques
- Limitations and Boundaries of DSP Based Solutions

Course Outline

1. **Introduction.** An examination of Past, Present, and Future Digital Modulation Systems.
2. **Digital Filters.** FIR Filters, Resampling Filters, Interpolators and Decimators, Half Band Filters, Cascade-Integrator-comb (CIC) filters, Hogenauer Filters, Multirate IIR filters.
3. **Channelizers.** Modulation and Demodulation. Design Techniques. Workload Comparisons.
4. **Filter Design Techniques.** Window Designs and Performance considerations. Equiripple Designs. System Considerations. Options to Improve System Performance. Finite Arithmetic Window Designs and Performance considerations. Equiripple Designs. System Considerations. Options to Improve System Performance. Finite Arithmetic.
5. **Digital Baseband Transmission.** The Nyquist Filter, Excess Bandwidth, Matched Filters, Square-Root Nyquist Filter, Shaping and Up-Sampling Filters.
6. **Pre-and Post-Signal Conditioning.** Analog Filters, Timing Jitter, Direct Digital Synthesizers, CORDIC processors, Digital Oscillators, Interpolating and Decimating Filters in A-to-D and D-to-A, AGC, DC Canceling, I-Q Balancing.
7. **Sigma-Delta Converters.** A-to-D, D-to-A, D-to-D. Multi-loop Converters, Wide-Band Converters. System Considerations.
8. **Carrier Centered Modulation and Demodulation.** Shaping and Interpolation, QPSK, QAM, Digital IF Options, OFDM, Legacy Analog modulation and Demodulation in DSP. FM Modulation and demodulation.
9. **Synchronization.** The Phase Locked Loop, Proportional plus Integral Loops, Phase Recovery, Band Edge Filters in Frequency Recovery, Timing Recovery, Polyphase Filters in Timing Recovery.
10. **Adaptive Filters.** LMS Algorithm, RLS Algorithm, Lattice Filters, Linear Equalization, Adaptive Equalization, Decision Feedback Equalizers, Constant Modulus (Blind) Equalizers.
11. **Modem Structures.** Wireline, Cable, Satellite, and Terrestrial modems and considerations.

What you will Learn

- How to Size and Design Efficient Digital Filters
- Effects of Finite Arithmetic on Different Filter Architectures
- Understand Multirate Signal processing for Sample Rate Changes
- Understand Multirate Signal processing for Intentional Aliasing
- DSP Based Signal Enhancement and Signal Conditioning
- DSP Based Synchronization Techniques
- Limitations and Boundaries of DSP Based Solutions



Topics

- Digital Filters
- Channelizers
- Filter Design Techniques
- Digital Baseband Transmission
- Pre and Post Signal Conditioning
- Sigma-Delta Converters
- Carrier Centered Modulation and Demodulation
- Synchronization
- Adaptive Filters
- Modem Structures

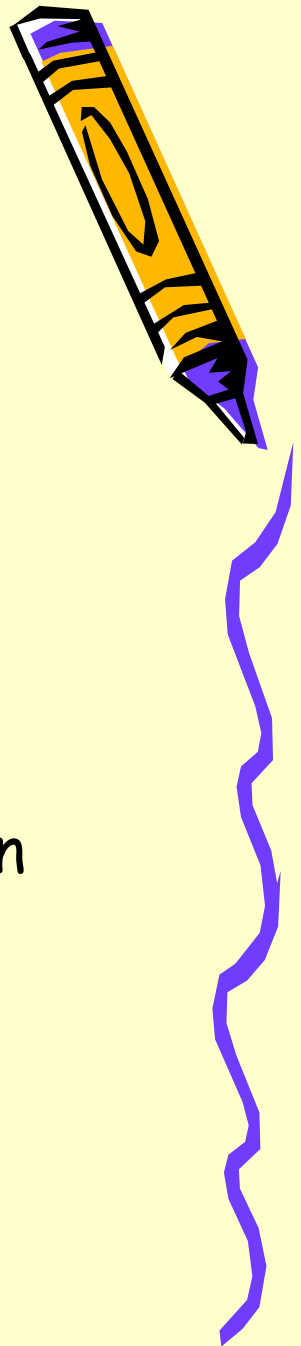

What the Customer Expects

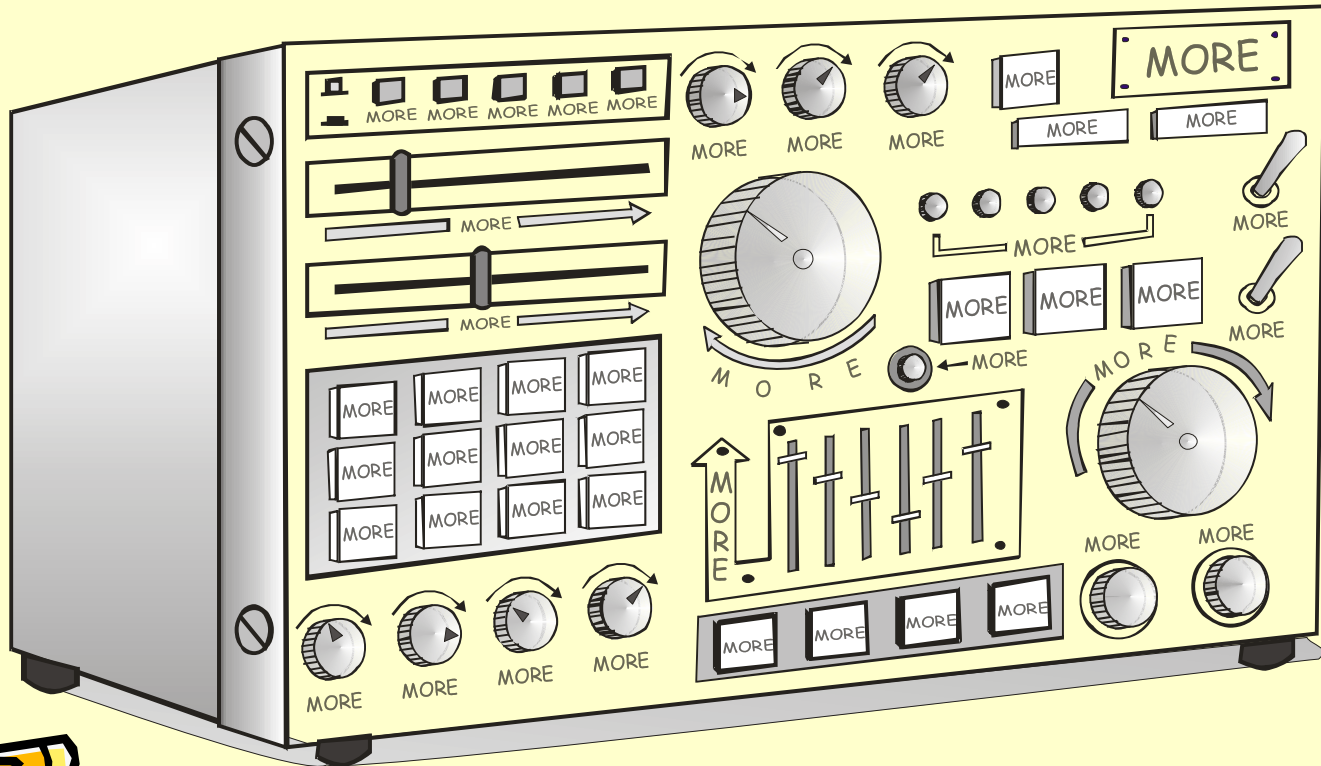

It all Started with....

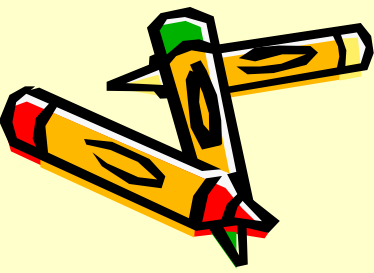
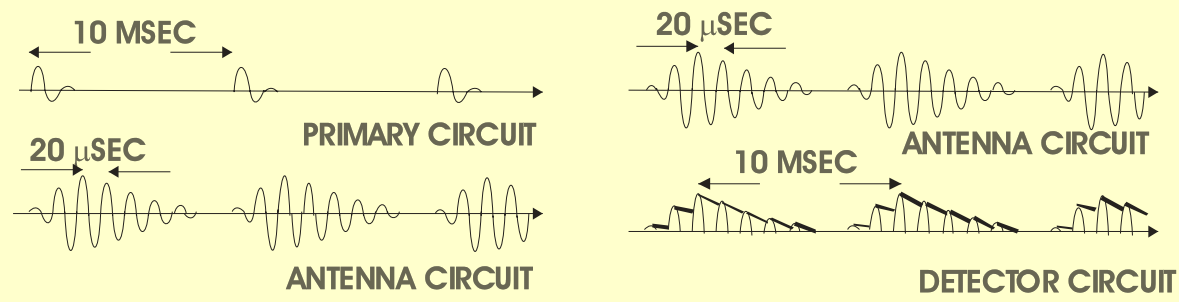
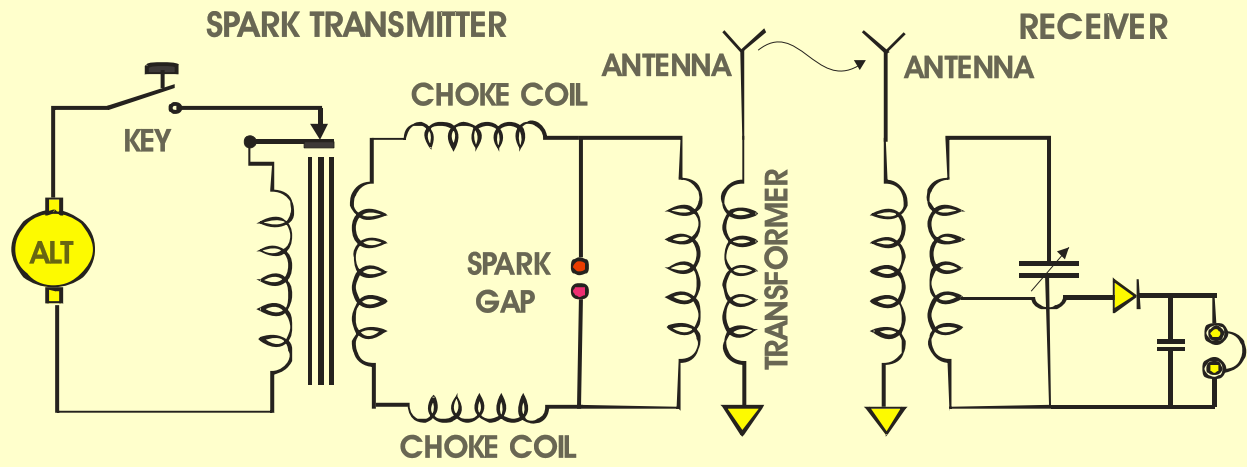
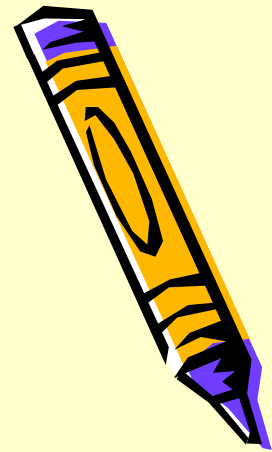

Regenerative Receiver

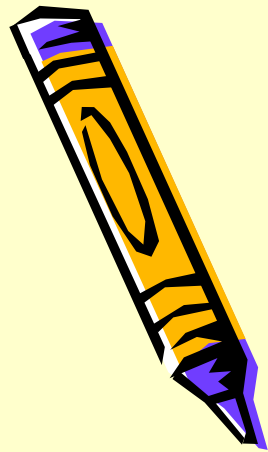
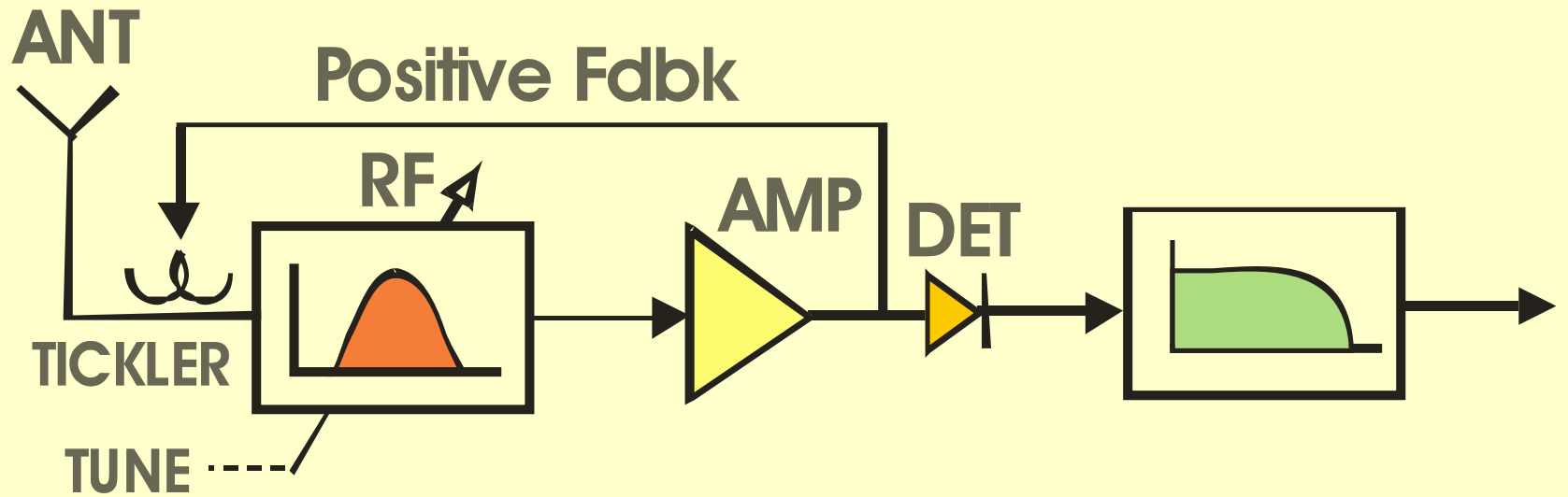

TRF: Tuned Radio Frequency

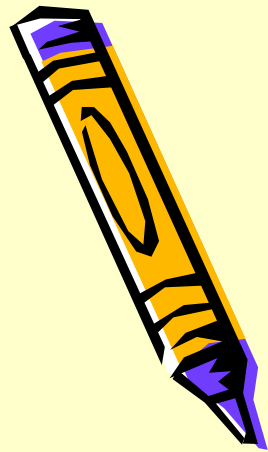
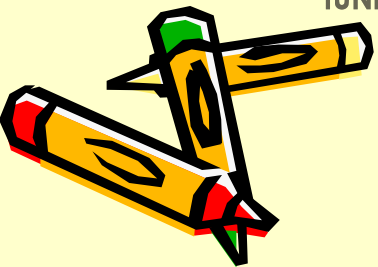
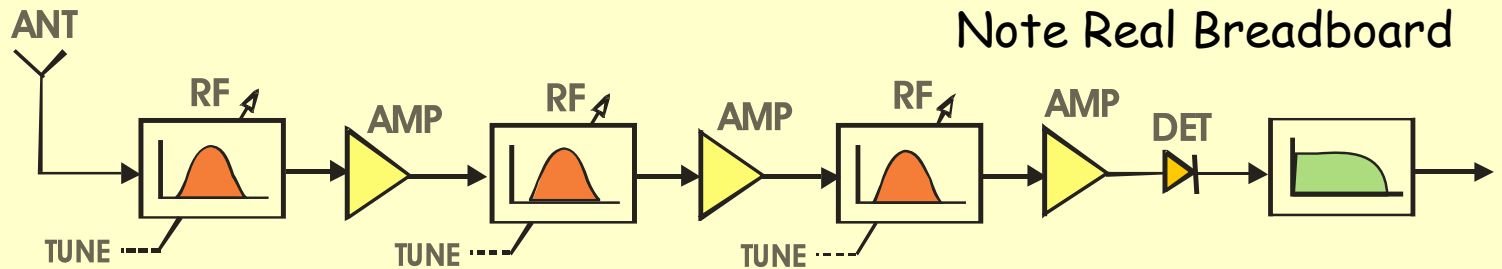
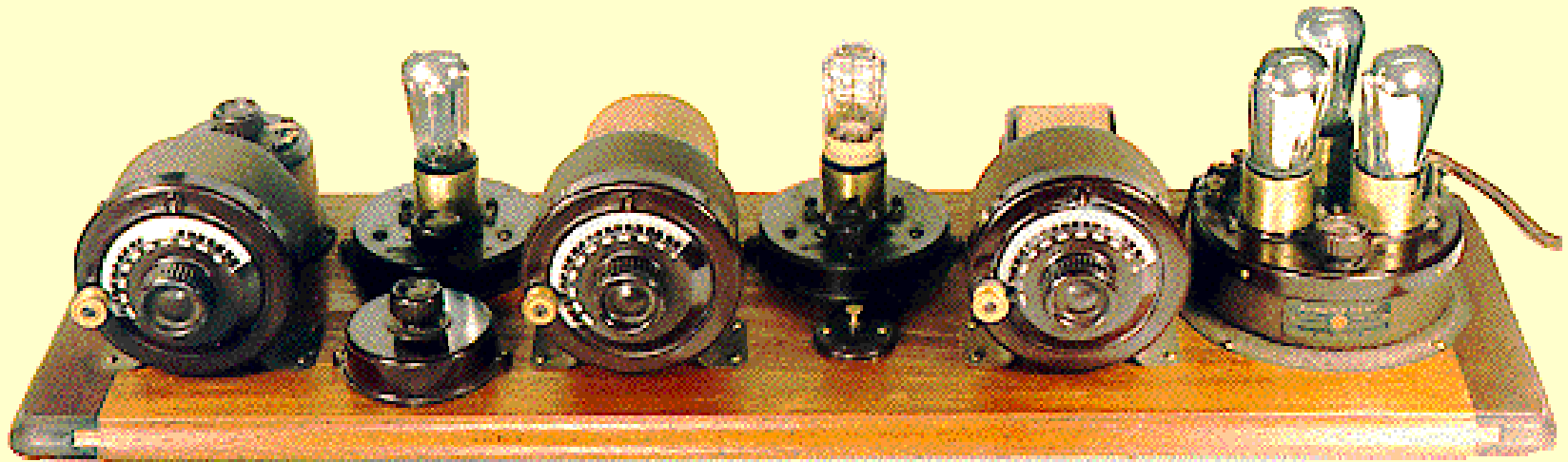

Superheterodyne

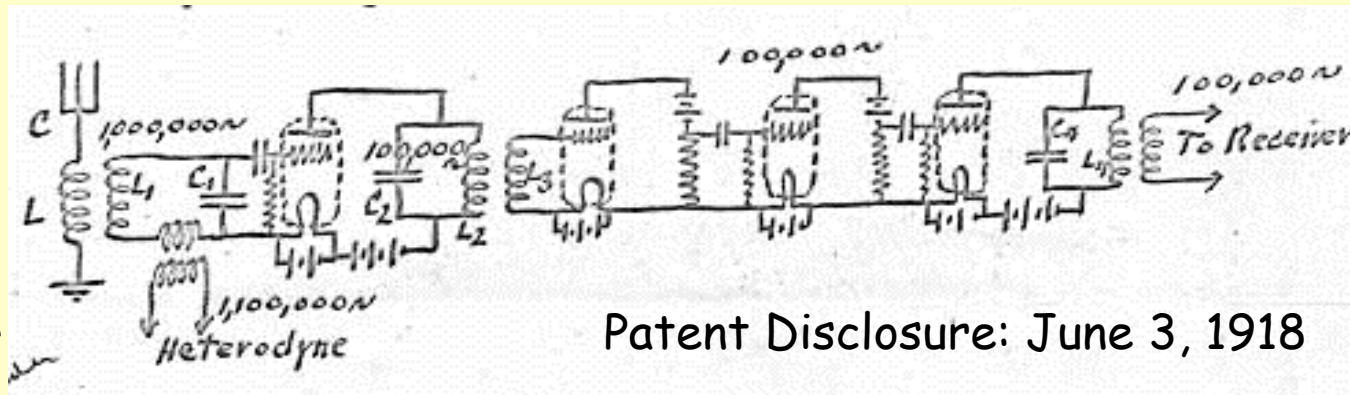
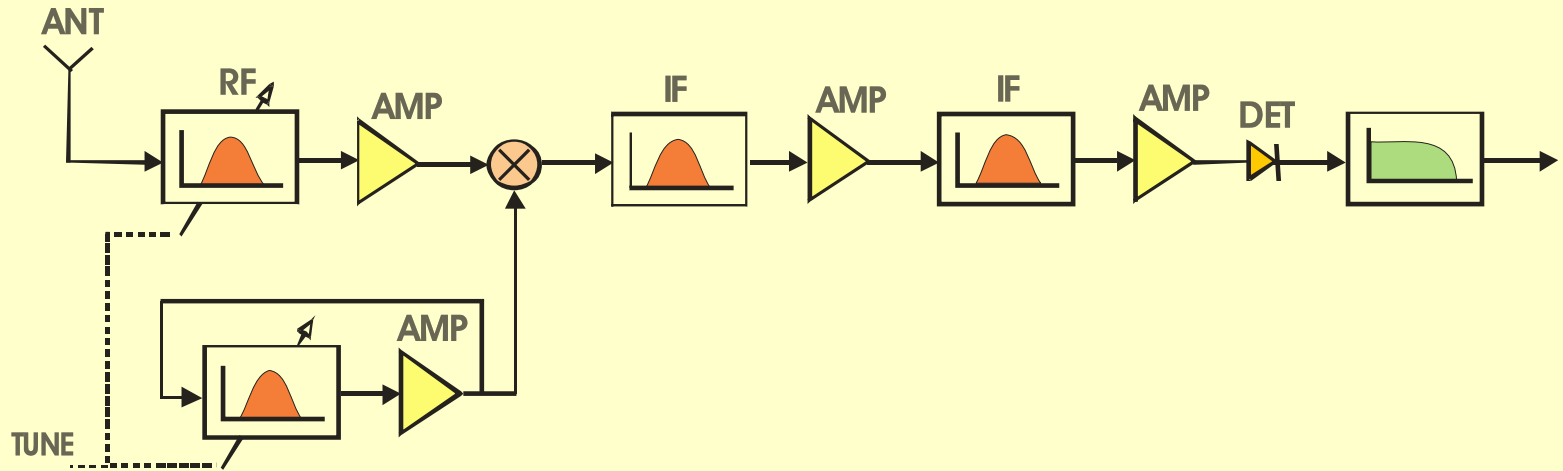

Patent Disclosure: June 3, 1918

Receiver Requires Copy of Carrier

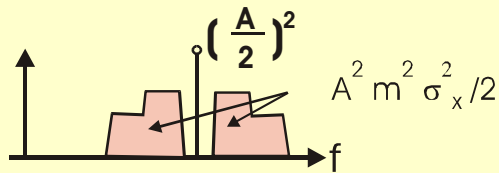
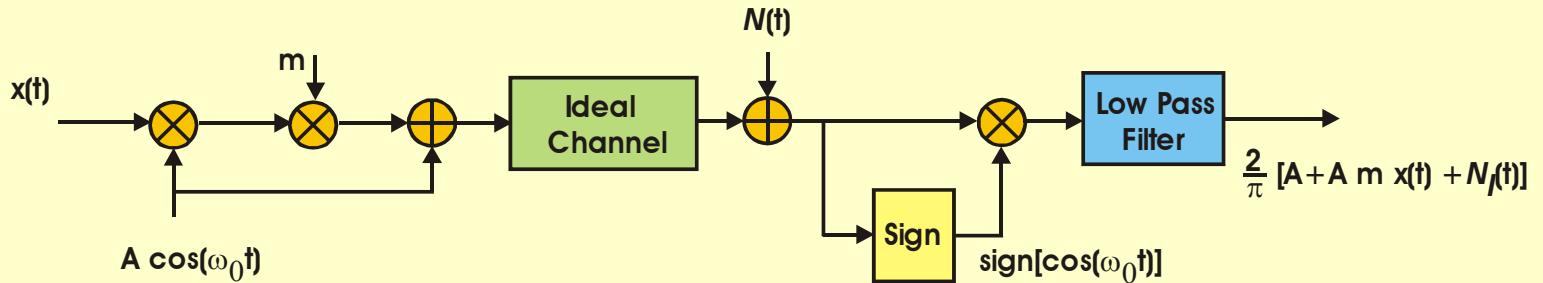
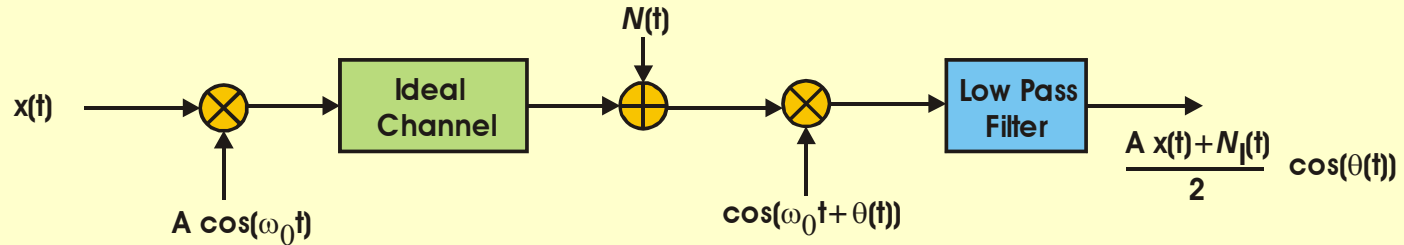

$m \sigma_x < 1/4$
 $m^2 \sigma_x^2 < 1/16$
95% energy in carrier



Carrier Recovery PLL

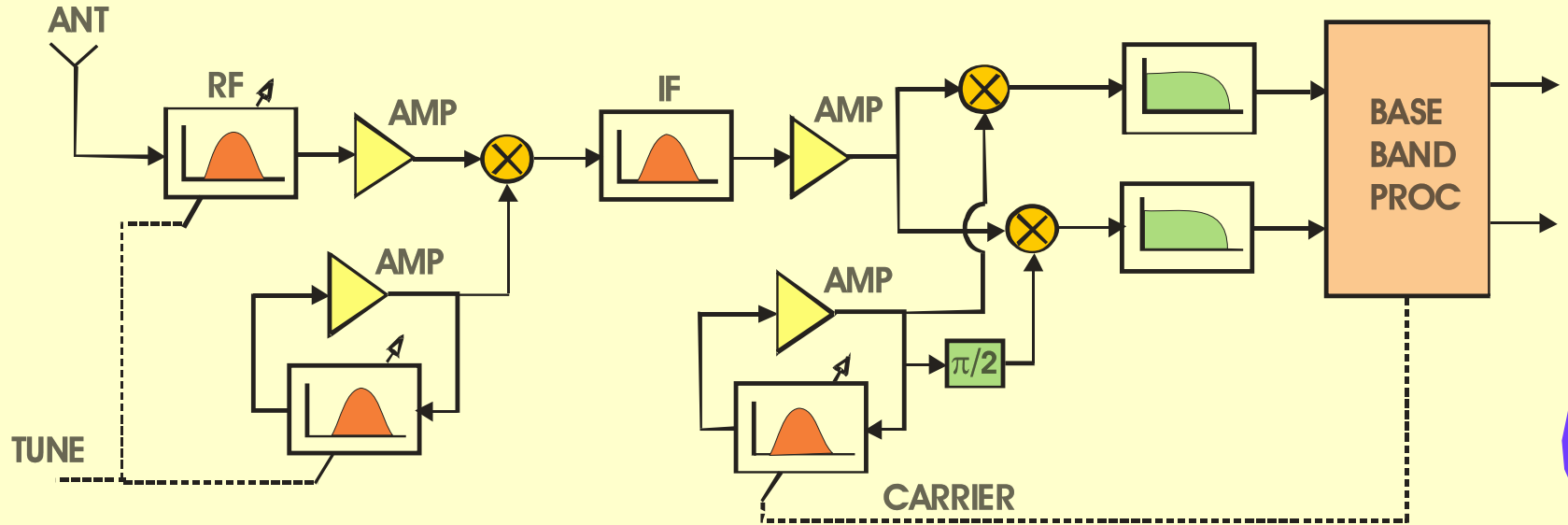

Harry Nyquist (1889-1960)

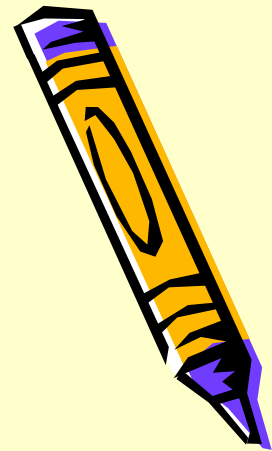

The Sampling Theorem

$$f_s > BW$$

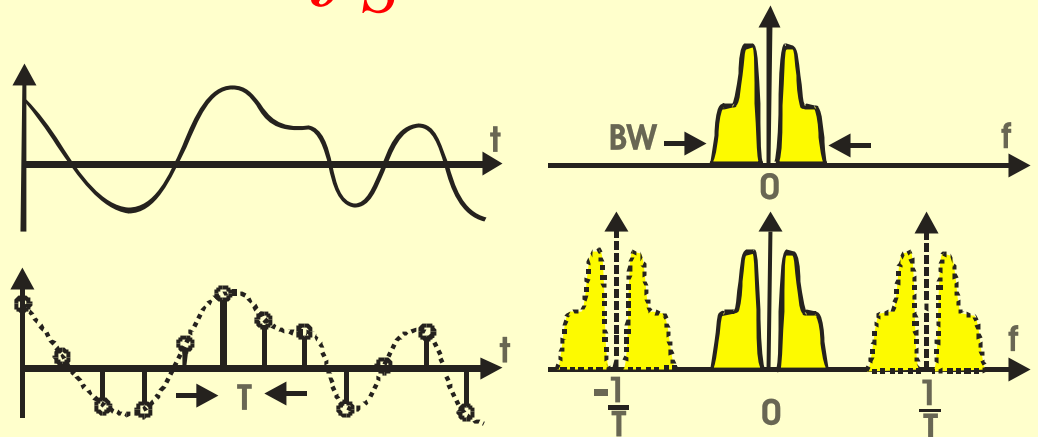

Analog to Digital Converter

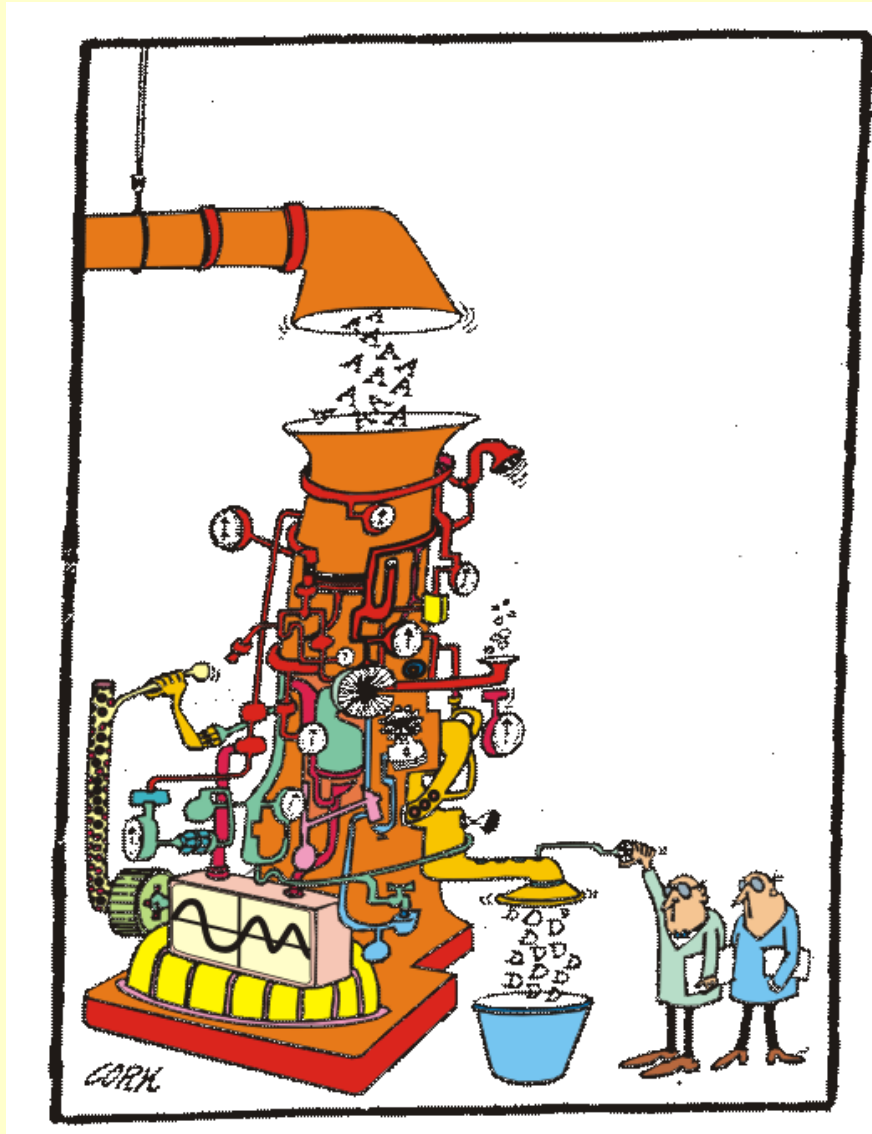

The Modern Era ADC and DSP Insertion

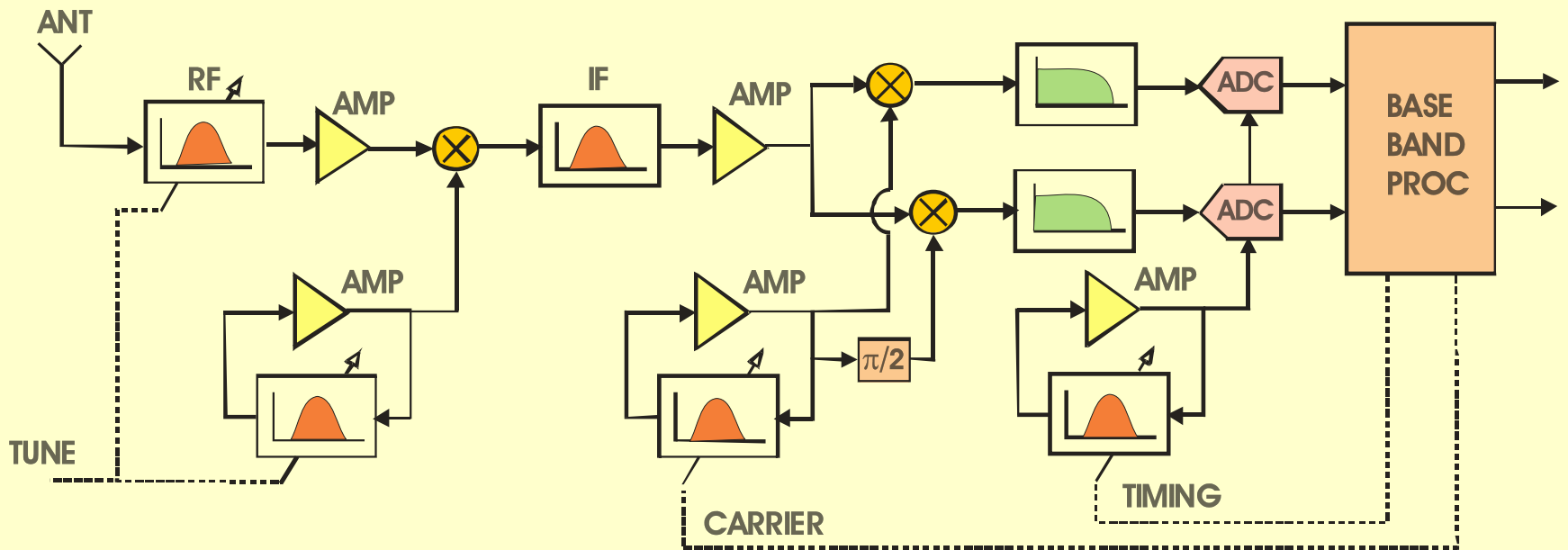

IF Sampling

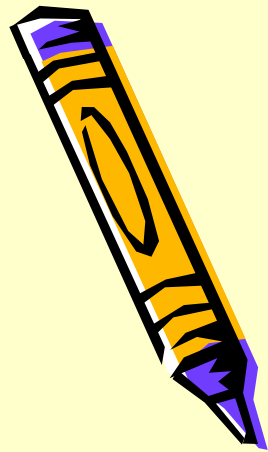
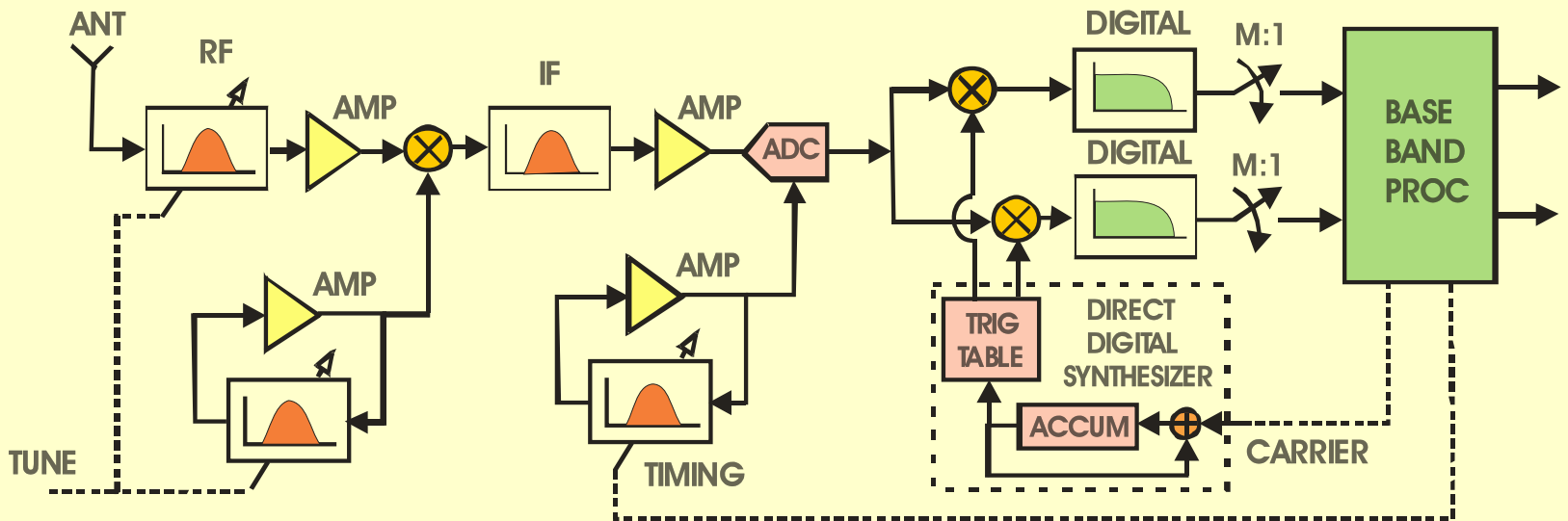

Timing Correction in DSP Land

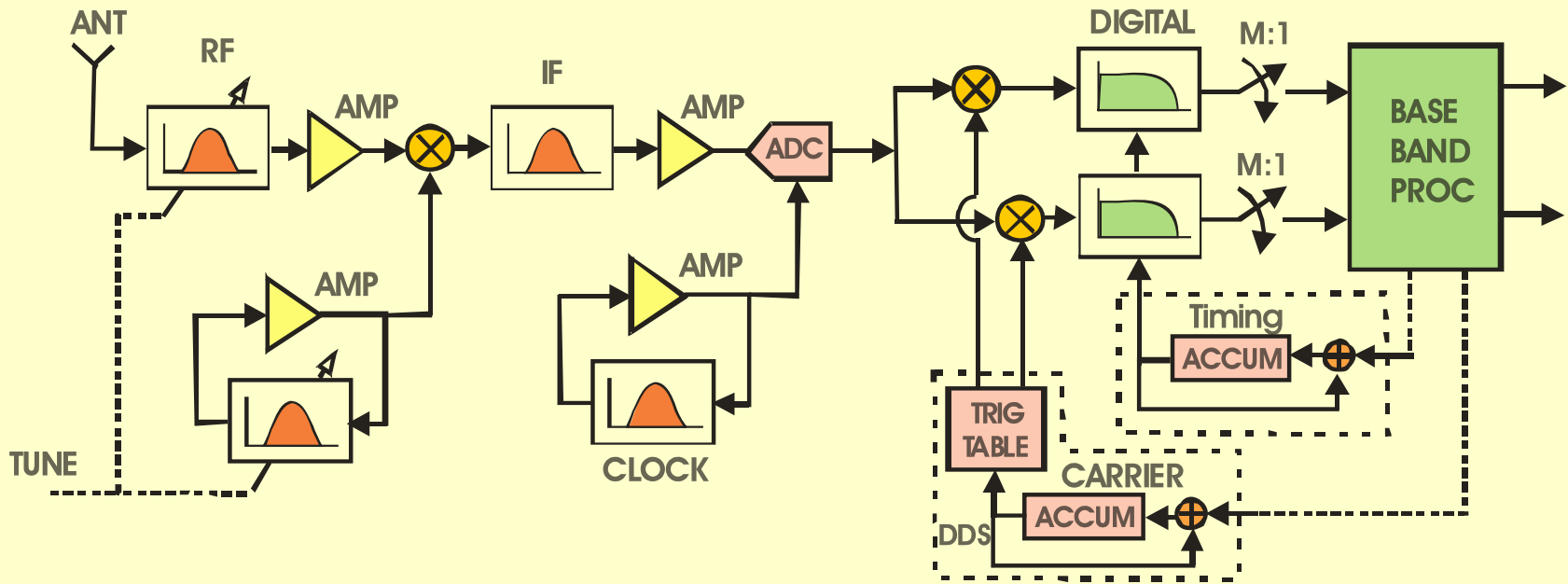

Digital Receiver: Asynchronous Carrier and Sampling Clock

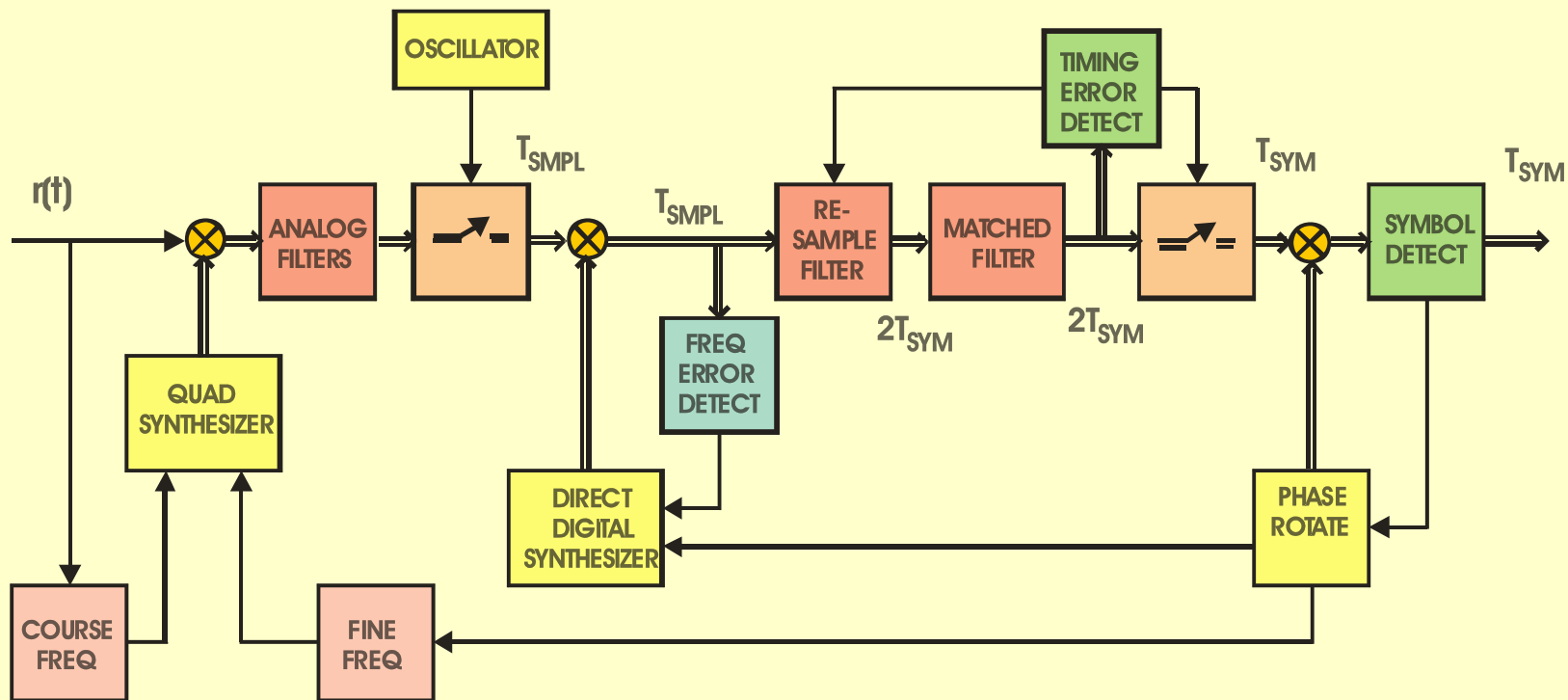
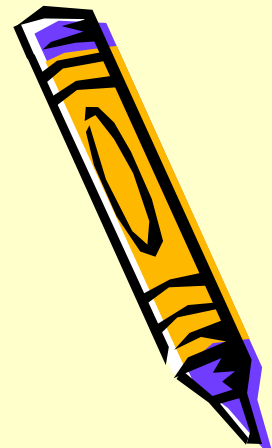

DSP Based Receiver

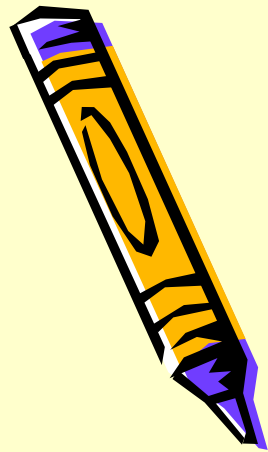
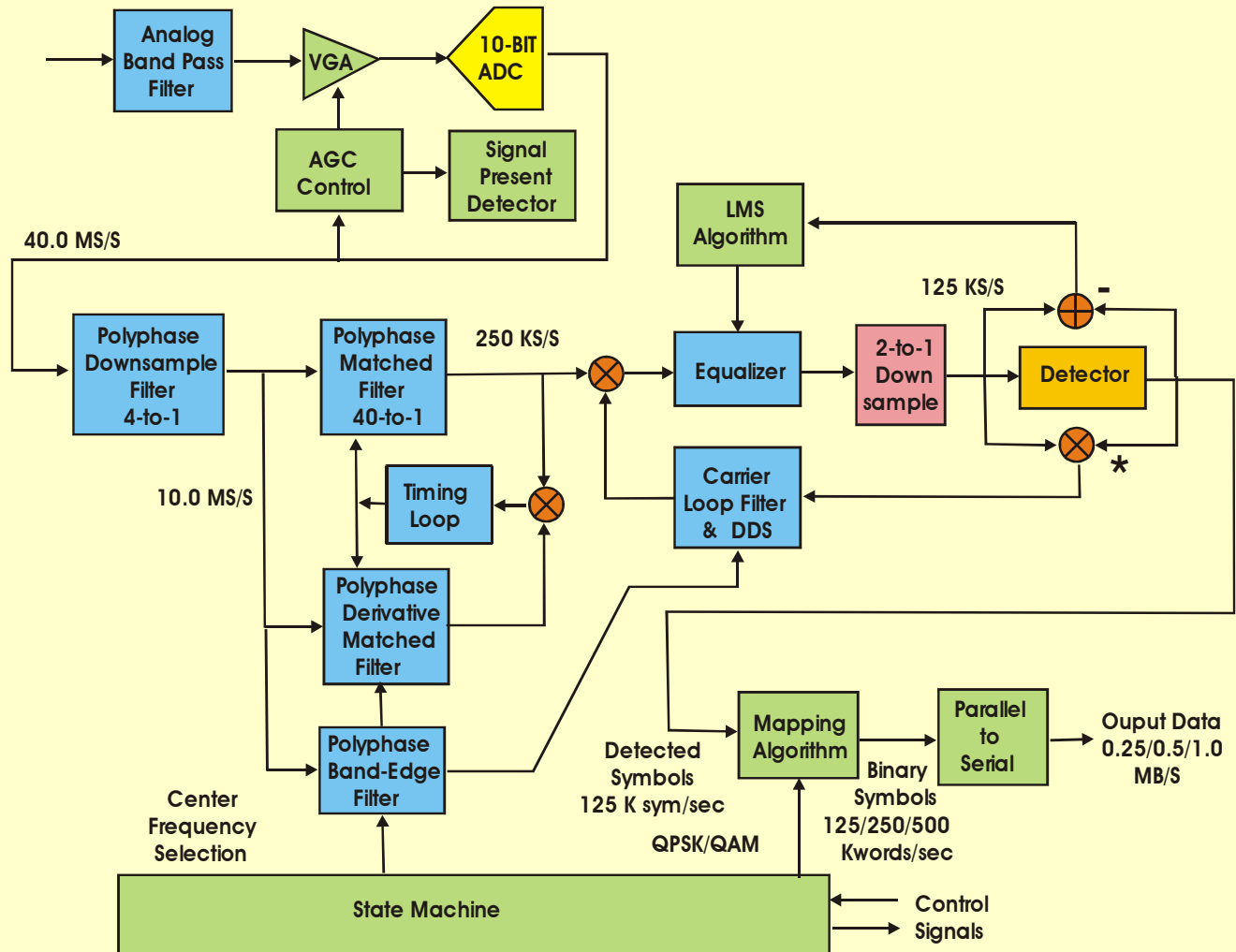

Polyphase Multichannel Receiver

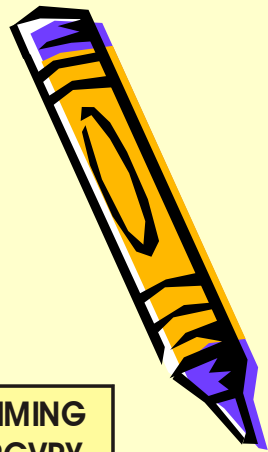
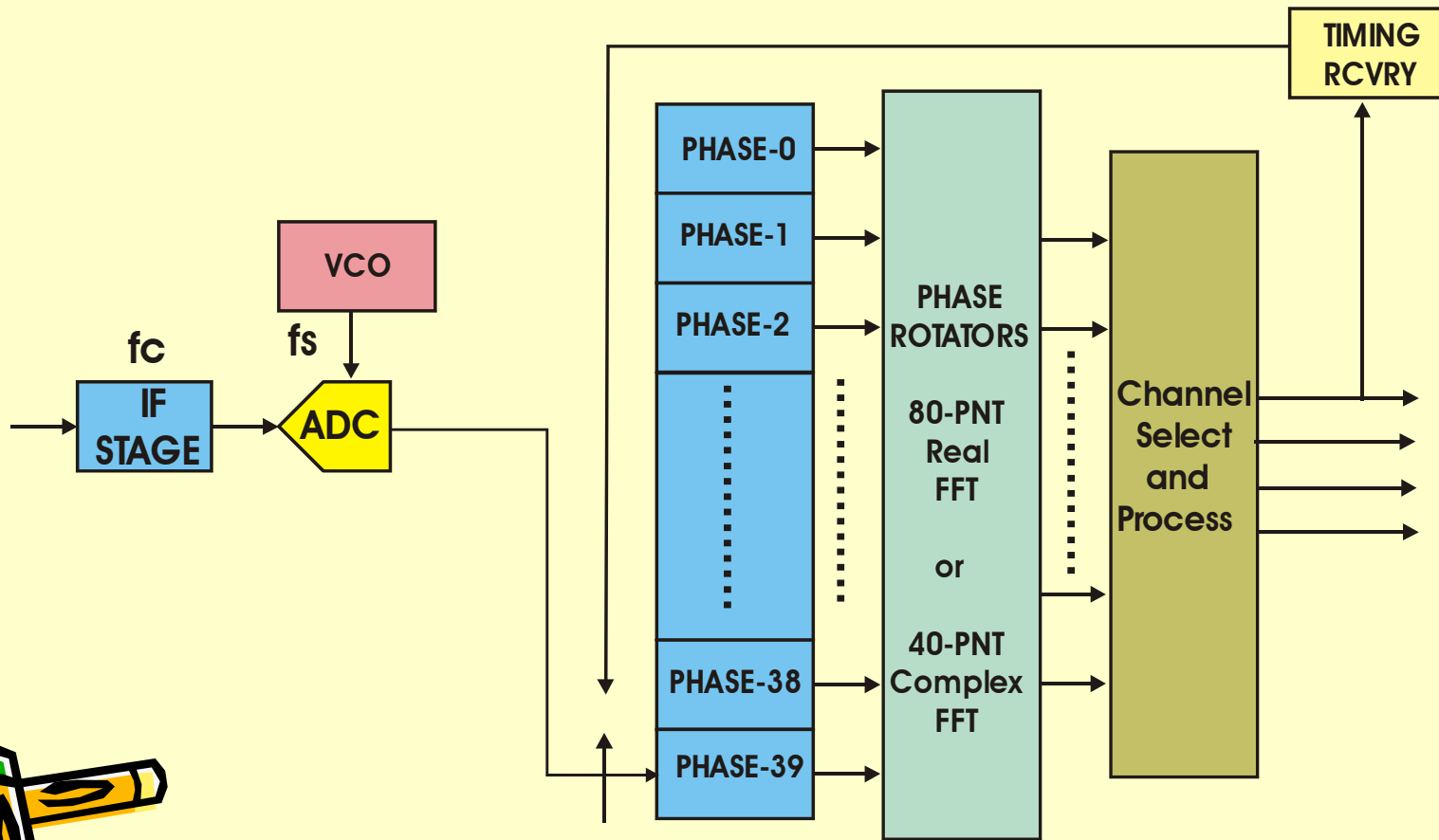

Time Series: 40-Channel Polyphase Filter Bank

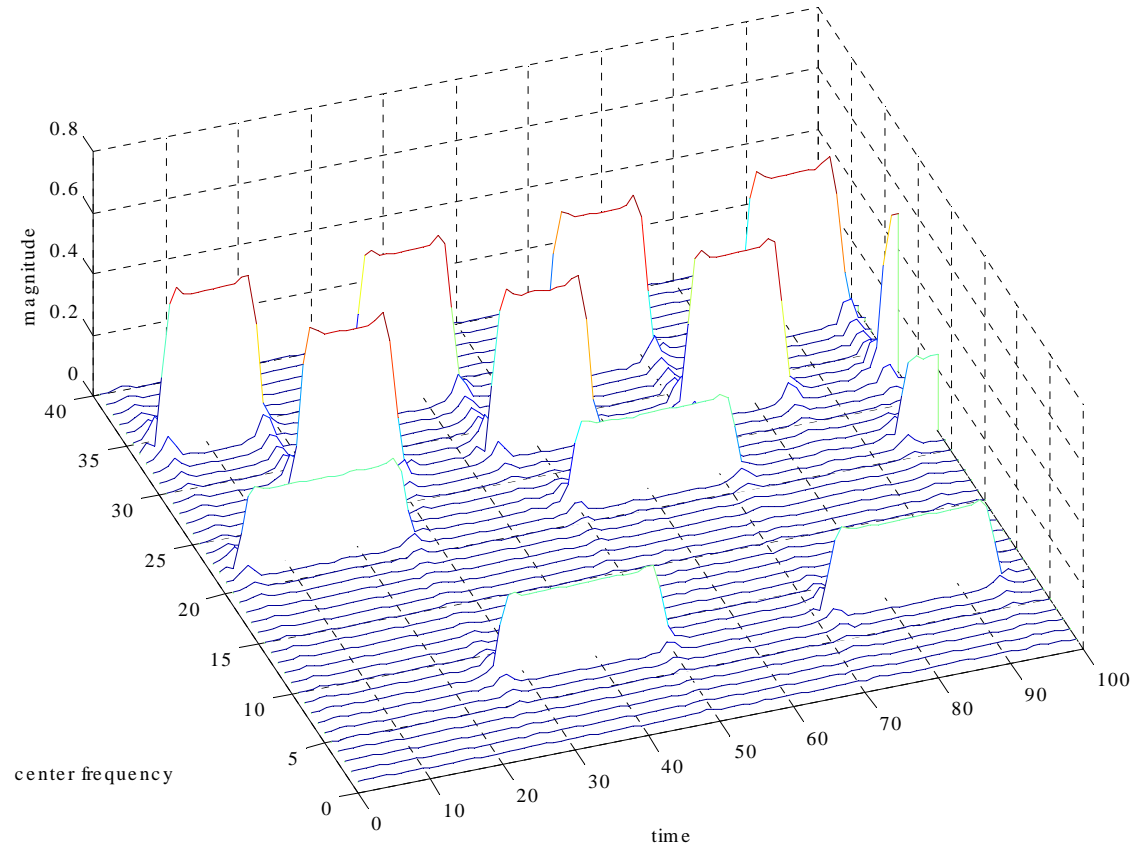
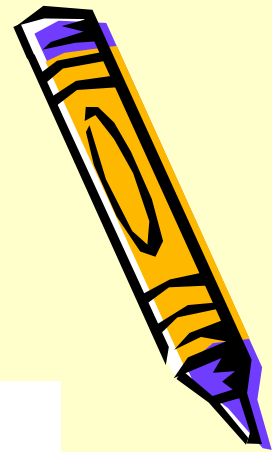

Polyphase Channelize 1-Wideband and 7-Narrowband CDMA Signals



Spectrum: S-1 at 6.144 MHz Spectrum: S-2 at 6.144 MHz Spectrum: S-3 at 6.144 MHz Spectrum: S-4 at 6.144 MHz Spectrum: S-5 at 6.144 MHz

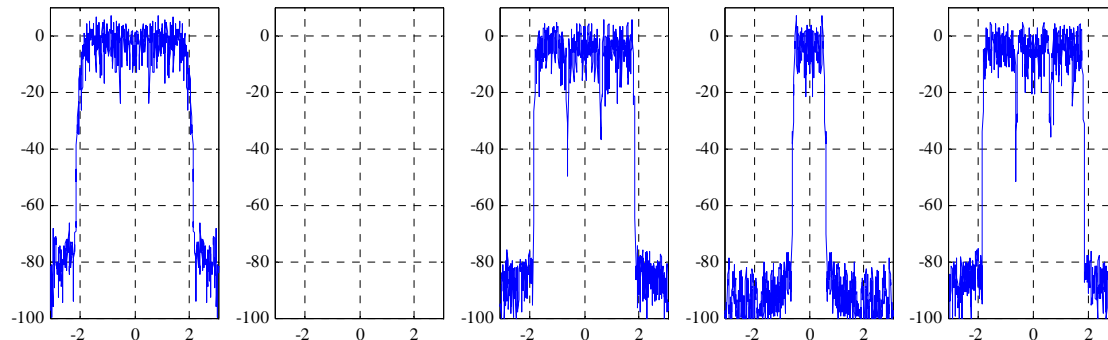

Spectra upsampled to 15.36 MHz and up converted in polyphase filter

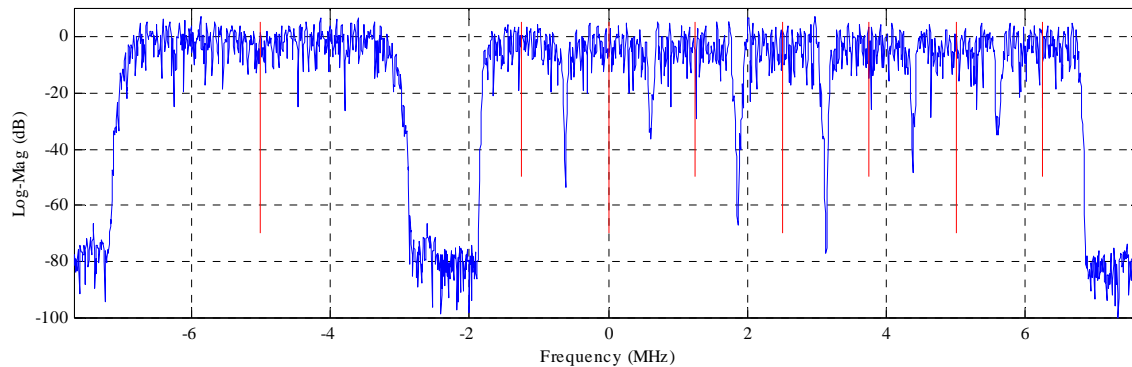

Related Publications

f.j harris,

“On the Relationship Between Multirate Polyphase FIR Filters and Windowed, Overlapped FFT Processing”, Twenty-third Annual Asilomar Conference on Signals and Computers, 1989.

- D. Elliot, Editor,

“Handbook of Digital Signal Processing: Engineering Applications”,
Academic Press, 1987, Chapter 8, “Time Domain Signal Processing with the DFT”, pp 639-666.

- f.j. harris and M. Rice,

“Multirate Digital Filters for Symbol Timing Synchronization in Software Defined Radios”,
IEEE Journal on Selected Areas in Communications, Vol. 19, pp. 2346-2357, Dec. 2001.

- f.j. harris, C. Dick, and M. Rice,

“Digital Receivers and Transmitters Using Polyphase Filter Banks for Wireless Communications”,
IEEE Microwave Theory and Techniques, Vol. 51, No. 4, April 2003, pp.1395-1412

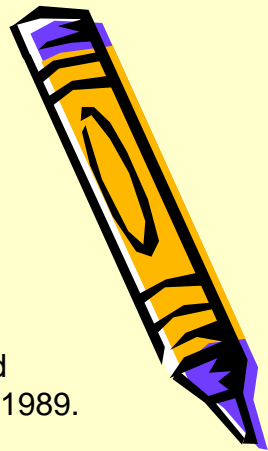

Boost Your Skills with On-Site Courses Tailored to Your Needs



The Applied Technology Institute specializes in training programs for technical professionals. Our courses keep you current in the state-of-the-art technology that is essential to keep your company on the cutting edge in today's highly competitive marketplace. For 20 years, we have earned the trust of training departments nationwide, and have presented on-site training at the major Navy, Air Force and NASA centers, and for a large number of contractors. Our training increases effectiveness and productivity. Learn from the proven best.

ATI's on-site courses offer these cost-effective advantages:

- You design, control, and schedule the course.
- Since the program involves only your personnel, confidentiality is maintained. You can freely discuss company issues and programs. Classified programs can also be arranged.
- Your employees may attend all or only the most relevant part of the course.
- Our instructors are the best in the business, averaging 25 to 35 years of practical, real-world experience. Carefully selected for both technical expertise and teaching ability, they provide information that is practical and ready to use immediately.
- Our on-site programs can save your facility 30% to 50%, plus additional savings by eliminating employee travel time and expenses.
- The ATI Satisfaction Guarantee: You must be completely satisfied with our program.

We suggest you look at ATI course descriptions in this catalog and on the ATI website. Visit and bookmark ATI's website at <http://www.ATIconourses.com> for descriptions of all of our courses in these areas:

- Communications & Computer Programming
- Radar/EW/Combat Systems
- Signal Processing & Information Technology
- Sonar & Acoustic Engineering
- Spacecraft & Satellite Engineering

I suggest that you read through these course descriptions and then call me personally, Jim Jenkins, at (410) 531-6034, and I'll explain what we can do for you, what it will cost, and what you can expect in results and future capabilities.

Our training helps you and your organization remain competitive in this changing world.